

# With your AM1000 you should find:



Some spare jumper shunts



Wire nuts

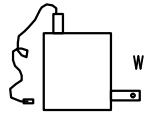

Wall transformer/ 12 volt power supply

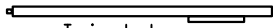

Tuning tool

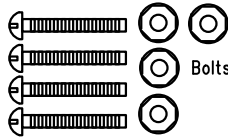

Bolts and nuts



Crystal (unless you ordered the AM1000A)



Ferrite



Transmitter

These items may or may not be included depending on what you discussed at the time of your order



600 ohm balanced to RCA jack audio adapter

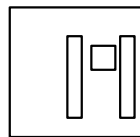

Frequency agile module (will be installed on board) (for AM1000A)

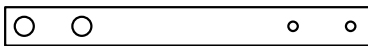

Audio attenuator



Transmitter Mount bracket kit

# AM1000 QUICK INSTALL INSTRUCTIONS

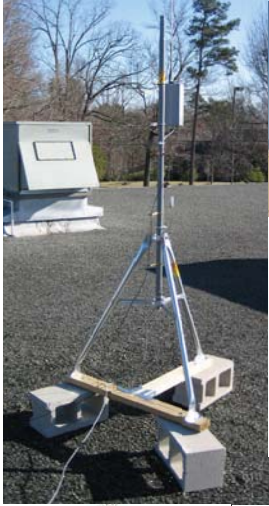

**Get Started!**  
Pick three locations 1) a place for the transmitter 2) place for your studio or inside connection (can just be under a desk) and 3) a ground. Once you have planned these locations so they will all work together you are ready!

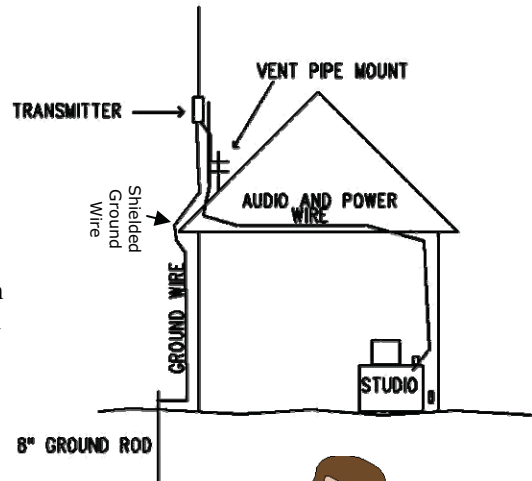

#15-530 Ground Rod

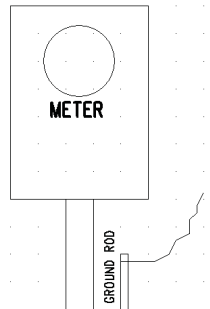

First, put your transmitter mount in, you can use standard 1 1/4 antenna mast mount from Radio Shack or an TV store. Be safe! Stay away from electrical wires and do not climb anything unsafe! Remember the antenna needs to be in the free air, not up against anything.



In Studio

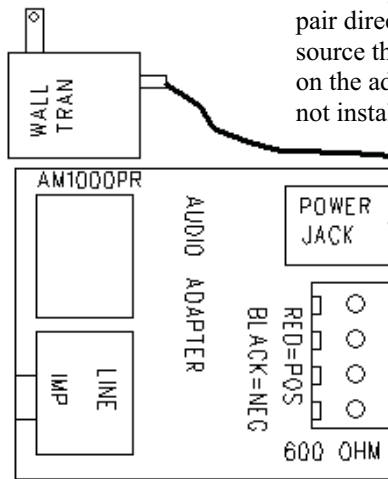

Next do your cabling; if you have a balanced audio source you can connect the audio pair directly to the transmitter, if you have an unbalanced (like a RCA jack) audio source then use the AM1000PR adapter as shown. Plug in your audio to the 1/8 jack on the adapter. Secure the control cable to the building or pole. (Note transmitter is not installed yet.) Ground the control wire shield at one end only.

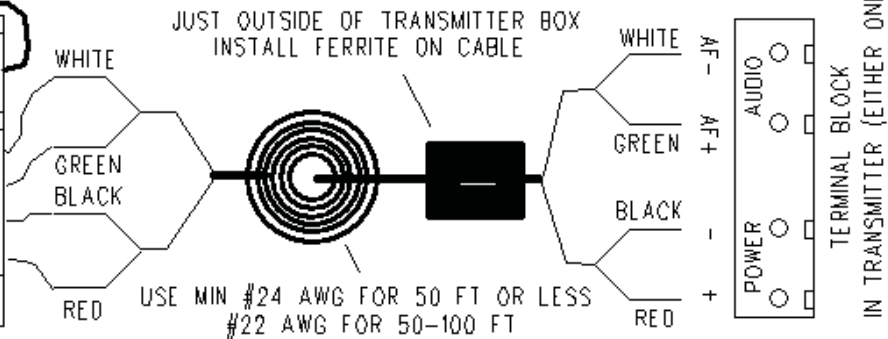

Ground Rod



Now run the ground wire, it can be #12 or #10, from the hardware store. The wire needs to take a direct path from the transmitter to a good ground for best lightning protection. It is best to keep the wire away from metal on the way down, see picture on the right. The ground wire is (stood off) from the mount using stand offs (see picture). The control cable (audio power) can just be wrapped around the mount. The ground wire needs to be secure so it won't move before you tune. All connections need to be tight, so they won't later corrode from weathering.





Now mount the transmitter to the mast using the bracket (see bracket instructions). If you are not using a bracket, install transmitter to wall or acceptable configuration. Install 102" Antenna (Radio Shack # 21-903) to the transmitter, it screws into the top.

Connect the audio/power wire as shown on first page diagram, the ground wire connects to the post at bottom of transmitter. Go ahead and connect power/audio and turn on. Be sure the power switch in the transmitter is ON. If your unit is crystal - controlled be sure the crystal is installed (socket to the middle right). If you are using the agile module, using the supplied chart, check your frequency.



It is possible to tune using the computer circuit, see the manual. Using a meter (available from RangeMaster) place the red lead in the bottom of the three test holes, the black lead in the top test hole, the middle hole is unused. The power control (bottom left of board) should be up about 1/3-1/2 turn. (The control near the middle of the board is the audio gain, turn it all the way down now for tuning). Set the meter to a low DC voltage, 10VDC, 20VDC is fine. This is the meter setup to take the VOLTAGE.

There is a 12 position header to the right of the large round red coil. Keeping your hands away from the antenna and coil best you can move the shunt up and down the header, try to find the position that gives the highest reading on the meter. This position should be near the middle of the range of the header. If there are two places where the voltage goes up, select the one near the middle.

Digital Volt Meter



Then using the provided tuning tool, turn the 10 turn device (capacitor) screw just to the right of the shunt, try to increase the voltage further. The goal is to find a peak voltage. You should be able to see the voltage go up, then down, as you rotate the tool. If not, if you go all the way to the end of the travel of the 10 turns, try another shunt position. You need to find the peak voltage in this step or you are not tuned and will not get good range. This tuning needs to be done when the transmitter is in it's final position, and with the ground wire locked down. You can not tune the transmitter first on the ground, & then install it. Find the peak voltage, & then leave it there. Now be sure to turn to audio level adjust pot back up.

Setting the power is easy, with the AM1000T "green light" simply rotate the power control until the LED at the bottom of the transmitter turns green. If you don't have the AM1000T, just refer to the "power chart" at the back of the manual for the proper readings of VOLTAGE and CURRENT combinations possible. VOLTAGE is read the same way as when you were tuning, to take the CURRENT reading just place the black lead in the bottom test hole and the red lead in the middle test hole, read the voltage on the digital meter. Rotate the power control until the readings are in line with the chart.

It's best to leave the audio adjust in the transmitter at 3/4 level, or all the way up, and adjust audio level from the ground. There is also a gain adjust in the AM1000PR audio adapter module. Adjust the audio level for good sound on a test radio. Your signal should sound as loud as other stations in the area. Get the audio level as high as you can without distortion. Try not to have the test radio too close to the transmitter, it can get overloaded.

RangeMaster Transmitters  
(919)367-0607

If you have trouble feel free to call, but check a few common problem first:

- Is your audio level high enough? Is it on? Audio is a gate on the power, if there isn't enough audio the range will suffer
- Check the voltage at the terminal block with your meter, is there at least 12 volts there?
- Low range is often a bad ground, it could be poor soil conductivity in your area, a broken ground wire, or your ground rod could be in sand or gravel instead of dirt. This is common when using an electrical meter rod, and/or if the rod is too close to a building foundation. If you can just push your rod in the ground it is probably just sand, and it won't work. Connections can't just be wrapped and taped, they need to be clamped. Clamps can be found at the hardware store. The copper needs to be bright and shiny and be tightly clamped or soldered. Use an 8 foot rod if possible. Isolate the ground wire from metal on the way down.
- Be sure you set the power properly
- Be sure the audio pot is turned up
- Be sure the crystal is in
- Here is a way to check transmitter operation: temporarily turn power up, you can draw a small spark from one of the round red coil leads or the antenna with a lead pencil if the unit is working correctly. If it is too bright you may not see the spark

# **HAMILTON**

RANGEMASTER AM1000

AM1000

INSTALLATION INSTRUCTIONS

OUTSIDE TRANSMITTER

AM1000  
213 CARAWAY LN  
Cary NC 27519

Please note that changes or modifications not expressly approved by RangeMaster for compliance could void the user's authority to operate the equipment.

## Installing the AM1000 transmitter

---

This unit is meant to be installed by someone who has some radio background. If you don't feel qualified to install this unit yourself contact a local radio/TV shop. They may be able to help. Also if you have a friend who is a Ham radio operator they may be able to help you. The goal of a successful installation is to achieve ½ mile range if the unit is near ground level. Within this ½ mile the signal should be clear and easy to hear. There may be some static mixed in, but the message being played should be clear. Up to a mile range and further may be possible if you have a good site and have the unit higher. A good height is 30 feet. Look around the structure and find a suitable place to mount the transmitter. It should be mounted as high as possible.

Keep in mind the cabling needs, a cable needs to run to the power and audio source. See included diagram for cabling example. Typically #24 (2) pair shielded cable is used for runs of 50 feet or less, #22 for up to 100 feet. Use one pair for + and – 12 volt and the other pair for the 600 ohm balanced audio. Connect the shield to ground at just one end. Also a ground wire needs to be run from the transmitter to a good ground for lightning protection. You can drive a 4 or better 8 foot ground rod into the ground for the lightning protection ground or use an existing ground. For best lightning protection the ground wire should have a direct path to dirt ground.

If you get low range and the tuning peak voltage range is low you may have a bad ground. Driving an 8 foot rod into soil should help you have a good ground. Don't get the rod too close to a house foundation. An electrical or pipe ground may not be reliable.

RF (radio frequency) can be tricky stuff. If you don't get results from your site, try another. The height is very important. The unit will not work unless it is tuned after it is installed in its final position. (You can't tune it on the ground first, it HAS to be tuned after everything is done, wires tacked into position so that they will not move.

Avoid putting the antenna near metal, especially large massive pieces of metal. Small metal pieces may be all right. You want to provide a stable environment around the unit. Attach any ground wire so that it will not move in the wind.

The antenna develops hundreds of volts of RF power. It won't shock you and can easily be quenched by even putting your hand close to it.

Once you've found a site sturdily mount the unit to the structure. Cable the ground wire to a good ground. Use #12 or #10 wire or larger (not aluminum) and run the wire directly down to your ground rod. The ground wire connects to the binding post on the bottom of the unit. If



#### Step 4

If things look good so far take the tuning tool and rotate "TUNE" to obtain a peak reading of the meter. When the meter peaks you are tuned. Be sure to stay away from the antenna while tuning. If you are too close to the antenna your body will affect where it tunes. Keep in mind that you need to see a peak. The meter should rise and fall as you adjust. If you just turn it clockwise or counter clockwise all the way and the meter goes up until the capacitor can't be turned anymore then it is not tuned.

You will get the most power with the least capacitance of the tuning cap that you can get to tune (counter clockwise). You may find that 2 jumper positions will tune. If so use the one that tunes with the "TUNE" in the most counter clockwise or least capacitance position. This will give you the best range and circuit performance.

#### Step 5

The next step is to adjust the power level. This simply involves taking 2 voltage readings and referring to the power chart in this manual adjust the power pot until you are at the legal power level. Turn the audio pot all the way down. Take your voltage reading, take this reading with the meter leads in the same position as when you were tuning. Now place your Black (negative) test lead in the bottom test hole pad & your Red (Positive) test lead in the middle test hole pad. This will measure your Current.

Your power should not exceed 100 milliwatts or .1 Watt to comply with FCC rules (Part 15). This would be acceptable. See the conversion table supplied for different combinations of Voltage and Current that equal 100 milliwatts. The "Power Adjust" works just like a volume control. Clockwise is more power and counter clockwise is less. With the AM1000T "Green light" simply adjust Power level control until the LED is green.

#### Step 6

Next connect your audio source. It is a good idea to leave the "aud" audio adjust  $\frac{3}{4}$  to all the way up "clockwise" and adjust the audio level from the ground. The Terminal block input is designed to work with a 600 ohm telephone cable like impedance. When you order the AM1000 you get an adapter that will convert 8 ohm (low imp 3.5mm) speaker type output or (high imp) like from a CD player to the required 600 ohm balanced audio. The new audio adapter has a gain control.

#### Step 7

Using a test radio tune to the transmitter frequency. The frequency used for this unit is often 1610 Khz . If the frequency is different it will be marked inside the unit. Look on the crystal (Y1). Once you pick up the signal on your test radio, (with no audio it will sound quiet with maybe a slight hum. Turn up your "AUDIO LEVEL" while listening to the test radio until you get distortion then back the "AUDIO LEVEL" off just a tad. If you are adjusting the audio level from the ground leave the "AUDIO LEVEL" set about  $\frac{3}{4}$  position. Your station should sound as loud as others in your area on a test radio, if you don't then there is a problem.

A scope is needed to be sure of 100% modulation. When the unit is being 100% modulated a test sine wave at the antenna will match the original audio waveform.

#### Step 8

Now go and check your range. Use your car and your odometer to check the range. Do the final tune on "TUNE" (Check to be sure the meter voltage is still peaked). Adjust "AUDIO LEVEL" control for best sound on your radio.

Keeping the antenna as vertical as possible will help your range. It is also critical to keep the antenna away from metal. Don't for example, mount the antenna so it runs up against, or parallel to a metal drain pipe.

Before you leave make sure that the customer knows that if they have any trouble with the transmitter to simply unplug the wall transformer or power supply. Because of the high RF voltage generated the unit can induce a signal into phone lines, stereos, and other equipment.

If you find that you are not getting good range check the transmitter ground system, if you notice that when tuning the unit that instead of a sharp peak in the voltage the voltage barely moves while you are tuning you probably have a bad ground. Electrical grounds will not always be acceptable, you may need to run a separate ground or find another ground. You could use a water pipe that is going to ground for example. Also if you are getting poor range make sure you have set the power properly. If you are having troubles recheck all wiring and connections. If you have carrier but no audio be sure the audio pot is turned up. Be sure the power is connected to the power terminals and not the sync terminals. Be sure the crystal is in and seated (unless you have the freq module). See the trouble page.

Section 15.219 Operation in the band 510 - 1705 kHz.

(a) The total input power to the final radio frequency stage (exclusive of filament or heater power) shall not exceed 100 milliwatts.

(b) The total length of the transmission line, antenna and ground lead (if used) shall not exceed 3 meters.

(c) All emissions below 510 kHz or above 1705 kHz shall be attenuated at least 20 dB below the level of the unmodulated carrier. Determination of compliance with the 20 dB attenuation specification may be based on measurements at the intentional radiator's antenna output terminal unless the intentional radiator uses a permanently attached antenna, in which case compliance shall be demonstrated by measuring the radiated emissions.

We recommend fully cooperating with the FCC and following all FCC rules. The FCC is an independent governmental agency, answerable only to congress, we cannot guarantee and/or we cannot be held responsible for what the FCC may do or decide in any particular situation.

POWER  
ADJUST

HAMILTON PCB DESIGN RAL. N.C. L1 COMP.

AM1000T  
Module  
(if  
installed)

COIL  
TUNE

Audio  
Level

SEE DRILL LAYER FOR IMPORTANT NOTES

CRYSTAL

TEST  
HOLES

CAP  
TUNE

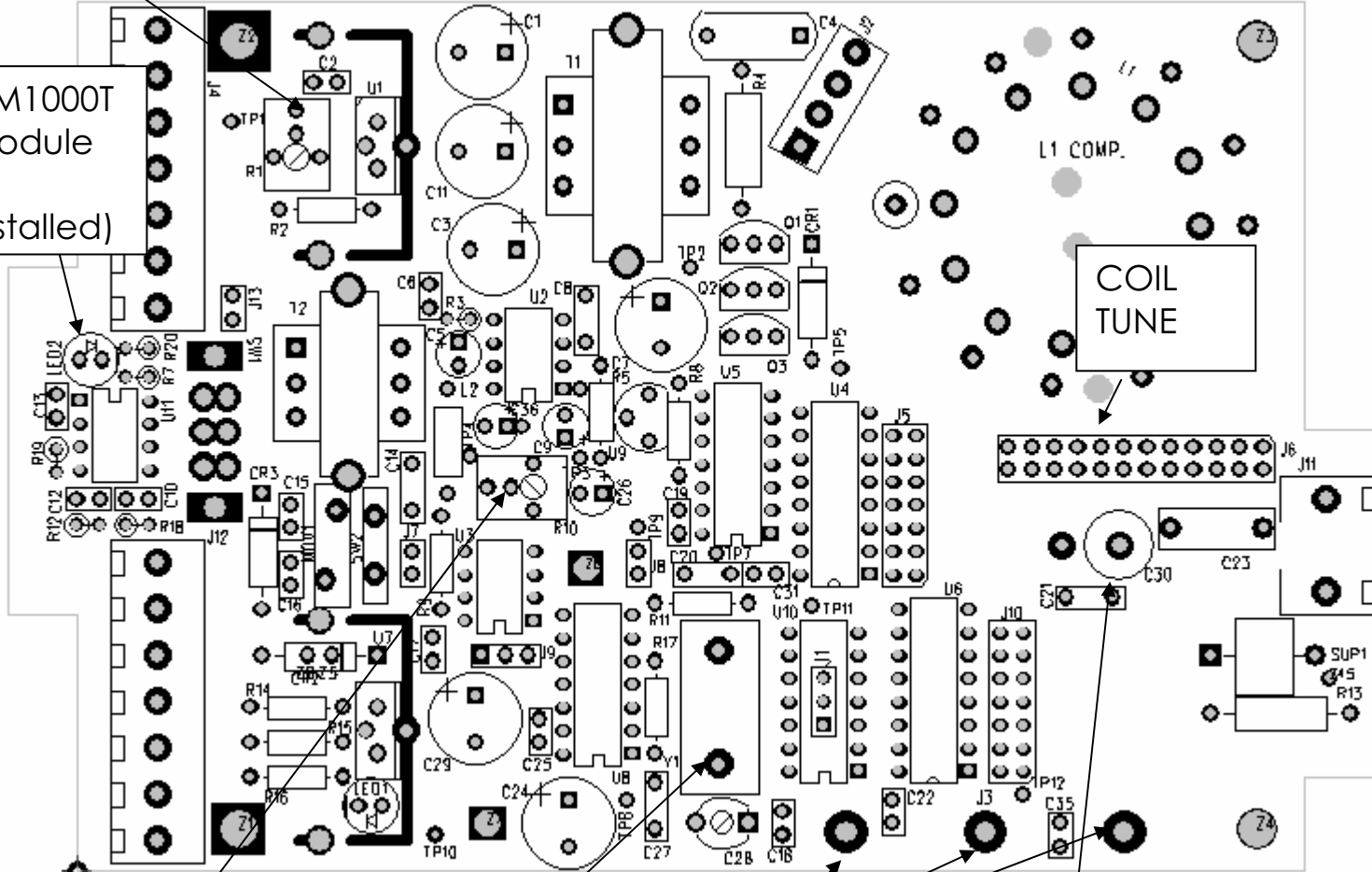

# AM1000T Tuning Computer

If your AM1000 is equipped with an AM1000T tuning module the multicolor LED will either blink green or turn solid green when your power level is at the FCC Part 15 legal 100 milliwatts. In some situations you may get a mirror shorter green LED reading at a higher power level, if you get 2 readings the correct one is the one with the power control at the more counter clockwise position, the mirror reading will be much shorter and may not show up at all.

If a shunt is installed in J13 the module functions as a tuning aid, as the power amp voltage goes up the LED will get greener. If you find that the LED gets suddenly red then you are going out of its range, turn the power pot on the transmitter down some. Start with the power pot at a low level. First find the correct Shunt position at J6. Start at the center, the correct position will be where you get the most Red Green change with C30 (Use included tool for C30) Then tune C30 for the most green, if the LED gets to full Green turn the power down some. After tuning set the power by removing the J13 shunt. Using a Volt Meter is a more accurate tuning method, see manual.

The shunts (J6) are located next to the large red round coil, C30 tuning is next to that.

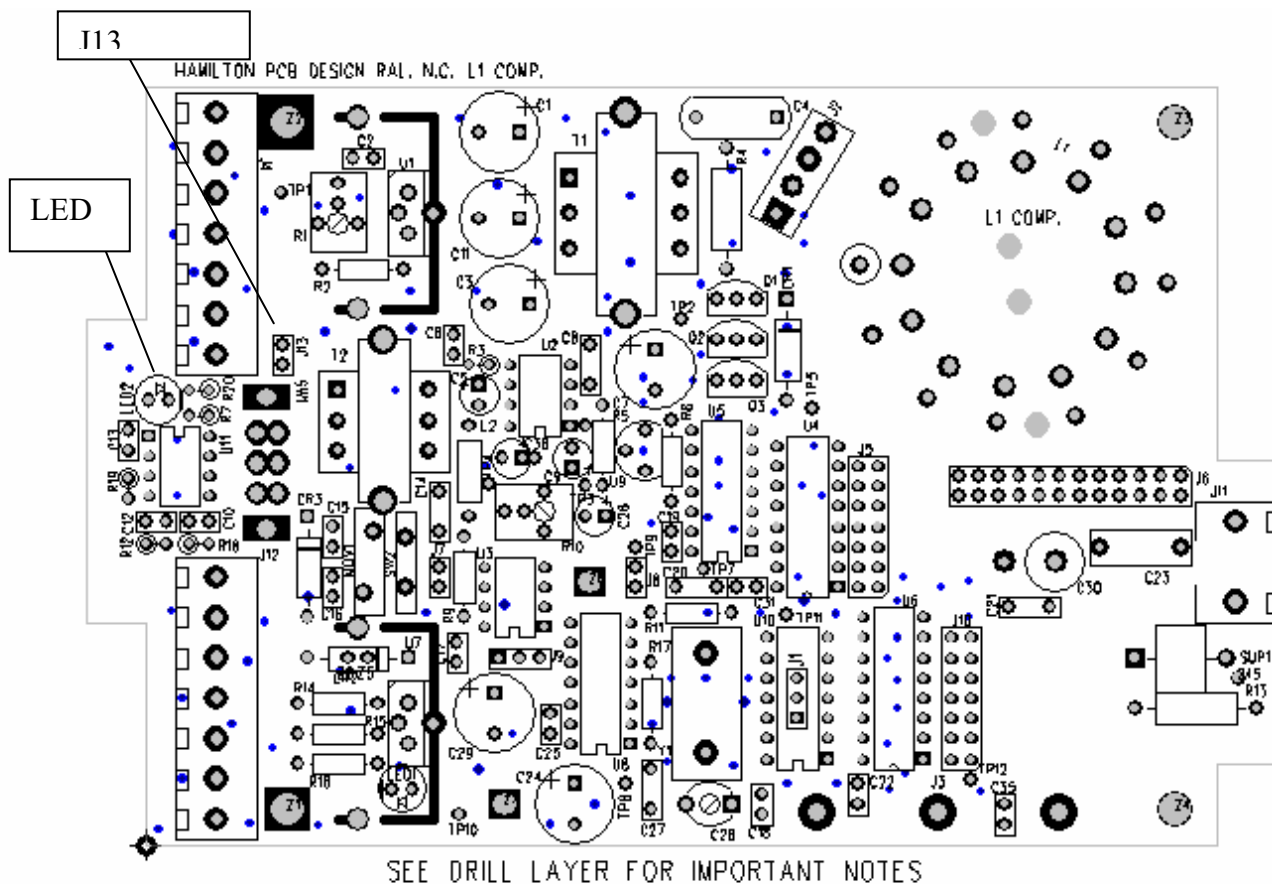



If you are using an Innovonics 222 be sure your output polarity is correct, here is how:

1. Turn the positive peaks all the way down
2. Turn the output level up until you get distortion, then back off a little (hair) for good sound.
3. Then turn the positive peaks all the way up, if you get distortion then the (output) terminals + and - are probably reversed.

The polarity of the input terminals doesn't matter.

If you are having trouble matching your input impedance to the Innovonics see the website for instructions. (How to hints, then audio button)

-Your station should sound as loud as others on the dial, if it doesn't there is a problem. It may be an audio impedance mismatch, or the level may need to be turned up. If the audio level isn't high enough you won't get good range, audio is a gate on the power, keep your audio turned up as high as you can.

-We have found the most common cause of low range is the audio setup, even more common than grounding problems. Not enough audio power (volume) and/or an impedance mismatch. If you are using an 8 ohm (low impedance) output which would be a headphone or speaker output that needs to be connected to the low impedance input on the audio adapter. Then the 2 screw terminal block needs to be wired via 2 wire twisted pair to the transmitter. If you plug the low impedance port of the adapter to a high impedance source like a line out jack you will have problems. An impedance mismatch will lower the audio level and reduce the fidelity, and may cause distortion. If you have a line out type source it needs to go to the high impedance jack on your audio adapter. In either case if you can't get the audio loud enough so it is as loud as other stations in your area without distortion then there is a problem in the audio chain.

To get more Range:

Try to locate the transmitter near something that will reradiate the RF energy such as high tension power lines. The signal will tend to follow lakes and rivers. Use as high a modulation level as you can. Get the unit as high as you can but not so high you can't safely get to it to tune it.

Troubleshooting:

-Check the voltage at the terminals of the transmitter, is there at least 12VDC there?

-Low range is often a bad ground. There could be bad soil conductivity in your area, or the ground rod could just be in gravel or sand instead of dirt. If you can just push the rod in with your hand then it won't be a good ground. Bad connections are often the problem. Just wrapping wire around a rod will NOT work. ALL connections need to be soldered or clamped. The copper needs to be bright and shiny before soldering or clamping. Be sure your ground wire is isolated and not wrapped around a metal mast or attached to metal siding or downspout. The ground wire should be isolated from all massive (bigger than a nail) metal. Use an 8 foot ground rod if at all possible. If you are using bigger than #12 wire (better) you won't be able to insert it into the binding post at the transmitter. Use a short (6") piece of #12 as a splice make the connection. Twist the #12 wire to the larger wire and twist a wire nut on. Be sure to weatherproof this with some silicone. Then put the other end into the ground binding post of the transmitter and tighten the binding post. If you find that your installation degrades after a few weeks you probably have a ground splice or connection that is weathering or corroding somewhere. This ground wire must be locked down and stable so it won't move. Electrical grounds will not always be acceptable, you may need to run a separate ground or find another ground. You could use a water pipe that is going to ground for example. See the hints page for an example of a good ground system.

-Check quality of ground- After tuning unit, with the tune voltage at about 2-3 volts (rotate PWR) rotate the Cap tune from the extreme counter clockwise position to the clockwise position while watching the meter. Make note of the voltage swing you see, less than 1.5 volt, bad or no ground. 1.5-2 volts poor to adequate ground. 2-3 volts, good ground. 3-5volts, great ground. This test will give you an idea where you stand with your ground quality.

-If you are getting poor range be sure you are setting the power properly.

-If you have carrier but no audio be sure the audio pot is turned up. Be sure the power is connected to the power terminals and not the sync terminals.

-Be sure the crystal is in and seated (unless you have the freq module).

-Is power switch on?

-Are you using the tuning tool provided?

-When the transmitter is working properly it is possible to see a small spark with a pencil lead placed close to the coil (large red round object) pins. You may need to turn the power up for it to do this. Or you may feel a slight RF burn to your finger if you lightly touch the pins of the coil.

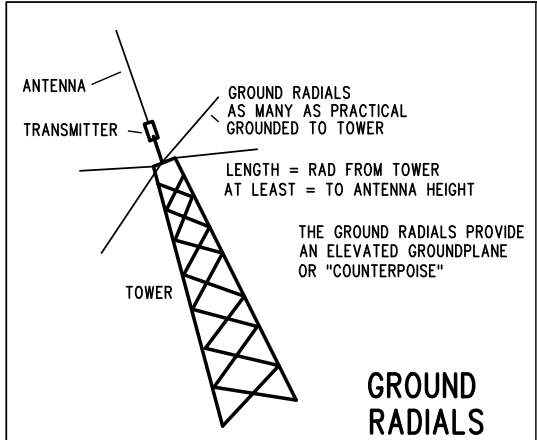

**GROUND RADIALS**

IF YOU AREN'T USING A TOWER SIMPLY MOUNTING THE TRANSMITTER OVER A GROUNDPLANE OR ELEVATED GROUNDPLANE WILL HELP. THIS CAN BE AS SIMPLE AS INSTALLING THE TRANSMITTER OVER A BUILDING THAT HAS A METAL ROOF. DESIGNING AN GROUNDPLANE IS COVERED ELSEWHERE ON THIS SITE. THE TRANSMITTER DOES REQUIRE A GOOD GROUND TO OPERATE, IT CAN BE AS SIMPLE AS USING THE EXISTING ELECTRICAL GROUND OR VERY COMPLEX AS WHEN USING MULTIPLE GROUND RODS AND BURIED RADIALS.

IF YOU TRY TO USE THE EXISTING ELECTRICAL GROUND OF A BUILDING YOU MAY NEED AN ELECTRICIAN. ANY GROUND YOU USE MUST BE ELECTRICALLY CONDUCTIVE. FOR EXAMPLE, IF YOU USE A METAL ROOF CHECK TO BE SURE IT IS ELECTRICALLY CONDUCTIVE ACROSS IT'S SURFACE.

ONE OF THE BEST WAYS TO GET MORE RANGE IS TO TAKE ADVANTAGE OF THE AM1000'S ABILITY TO BE MODULATED +130%. THERE ARE MANY AUDIO PROCESSORS ON THE MARKET THAT WILL DO THIS, THE CHEAPEST IS THE INNOVONICS 222. SEE INOVON.COM THE OPTIMOD IS ALSO AN EXCELLENT UNIT. ANOTHER TIP FOR GETTING GOOD RANGE IS TO OVER MODULATE A BIT.

- Section 15.219 Operation in the band 510 – 1705 kHz.
- (a) The total input power to the final radio frequency stage (exclusive of filament or heater power) shall not exceed 100 milliwatts.
  - (b) The total length of the transmission line, antenna and ground lead (if used) shall not exceed 3 meters.
  - (c) All emissions below 510 kHz or above 1705 kHz shall be attenuated at least 20 dB below the level of the unmodulated carrier. Determination of compliance with the 20 dB attenuation specification may be based on measurements at the intentional radiator's antenna output terminal unless the intentional radiator uses a permanently attached antenna, in which case compliance shall be demonstrated by measuring the radiated emissions.

Always cooperate with the FCC and follow FCC law.  
**Note:** The FCC may not pass some of the grounds on this page (ex elevated ground).

ANOTHER TRICK IS TO KEEP IN MIND THAT ANY CONDUCTOR IN THE AIR THAT ISN'T GROUNDED WILL CARRY YOUR SIGNAL. HIGH TENSION POWER LINES CAN CARRY YOUR SIGNAL FAR IF YOU CAN INDUCE YOUR SIGNAL INTO THEM. EVEN YOUR BACKYARD CLOTHESLINE CAN ACT AS A RADIATOR IF IT IS METAL WIRE AND HAPPENS TO BE INSULATED AT THE ENDS. YOUR SIGNAL CAN BE PICKED UP AND RE-RADIATED. KEEP THIS IN MIND & LOOK FOR CONDUCTORS LIKE THIS WHEN LOOKING FOR A SITE FOR YOUR LOW POWER TRANSMITTER.

ANOTHER HINT IS WATER. YOUR SIGNAL WILL CARRY WELL OVER OPEN WATER.

HEIGHT IS VERY IMPORTANT, BUT DON'T GET THE UNIT SO HIGH THAT YOU CAN'T GET TO IT TO TUNE IT PROPERLY. IT'S IMPORTANT THAT IT BE HIGH, BUT IT'S CRITICAL THAT IT BE TUNED. THE UNIT WON'T WORK AT ALL IF IT'S NOT TUNED PROPERLY. 25-30 FEET IS USALLY GOOD FOR HEIGHT, MORE WILL GET MORE RANGE BUT THE MOST BANG FOR THE BUCK IS 25-30 FEET.

- TO GET GOOD RANGE:
- 1- ELEVATED GROUDPLANE
  - 2- GET IT HIGH.
  - 3- USE AN AUDIO PROCESSOR.
  - 4- USE ISOLATED GROUND LEAD
  - 5- ELEVATED OR BURIED RADIALS

*The 3-meter combined length specified in Section 15.219(b) refers to the length of all radiating elements. Attaching the ground lead to an unshielded radiating object, or the addition of a ground screen, will cause the effective length of radiating elements to exceed 3 meters, in violation of Section 15.219(b).*

THE ABOVE IS SOME RECENT FCC POLICY. KEEP IN MIND THAT WHILE SOME IDEAS ON THIS PAGE MAY IMPROVE RANGE, FCC AGENTS MAY NOT APPROVE .

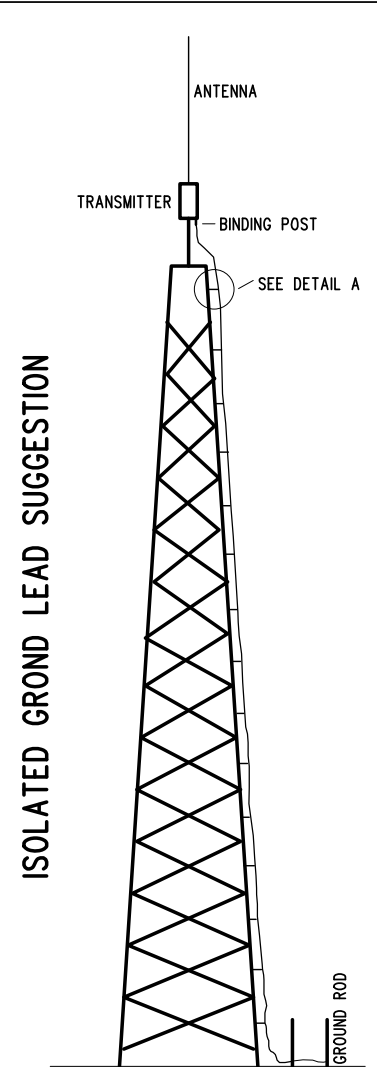

**ISOLATED GROUND LEAD SUGGESTION**

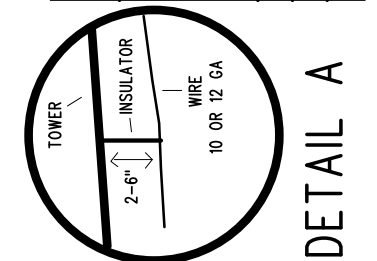

INSULATOR CAN BE CERAMIC OR ANY GOOD STRONG NON-CONDUCTIVE MATERIAL. PLASTIC WOULD BE OK.

**COPY**

FEDERAL COMMUNICATIONS  
COMMISSION  
WASHINGTON, D.C. 20554

**COPY**

GRANT OF EQUIPMENT  
AUTHORIZATION  
Certification

Hamilton PCB Design  
134 Wind Chime Ct. P.O. Box 20594,  
Raleigh, NC 27619  
United States

Date of Grant: 07/17/1998  
Application Dated: 05/08/1998

Attention: Keith Hamilton

**NOT TRANSFERABLE**

EQUIPMENT AUTHORIZATION is hereby issued to the named GRANTEE, and is VALID ONLY for the equipment identified hereon for use under the Commission's Rules and Regulations listed below.

**FCC IDENTIFIER:** NWXAM1000

**Name of Grantee:** Hamilton PCB Design

**Equipment Class:** Part 15 Low Power Communication Device Transmitter

**Notes:**

<u>Grant Notes</u>	<u>FCC Rule Parts</u>	<u>Frequency Range (MHZ)</u>	<u>Output Watts</u>	<u>Frequency Tolerance</u>	<u>Emission Designator</u>
37	15C	1.2 - 1.71			

37: This device has shown compliance with new rules adopted under Docket 87-389 and is not affected by Section 15.37, transition rule.

Mail To:

9805218315166002

We have found the most common cause of low range is the audio setup, even more common than grounding problem. Not enough audio power (volume) and/or an impedance mismatch. If your station is not as loud as other stations in your area without distortion then there is a problem in the audio chain.

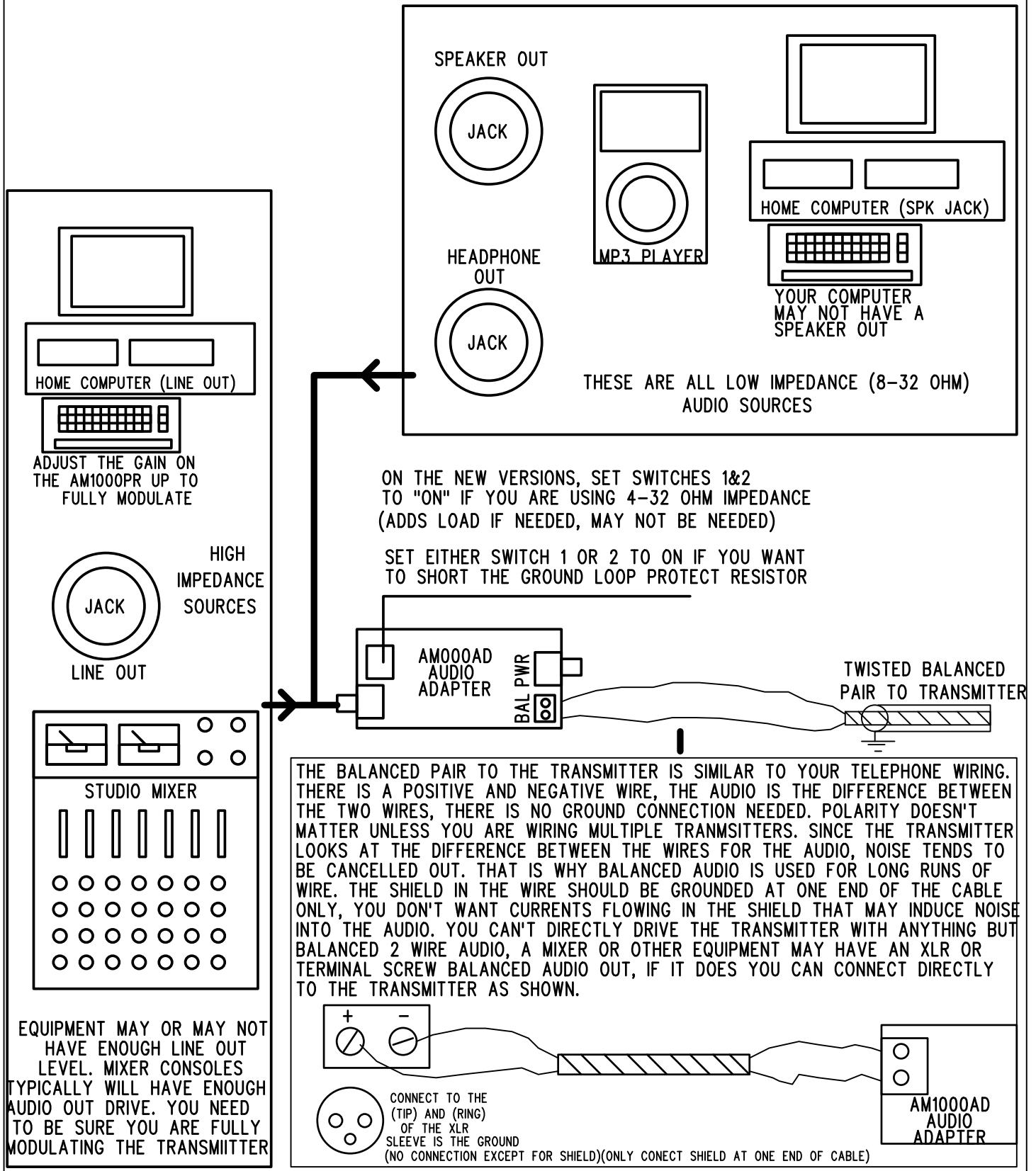

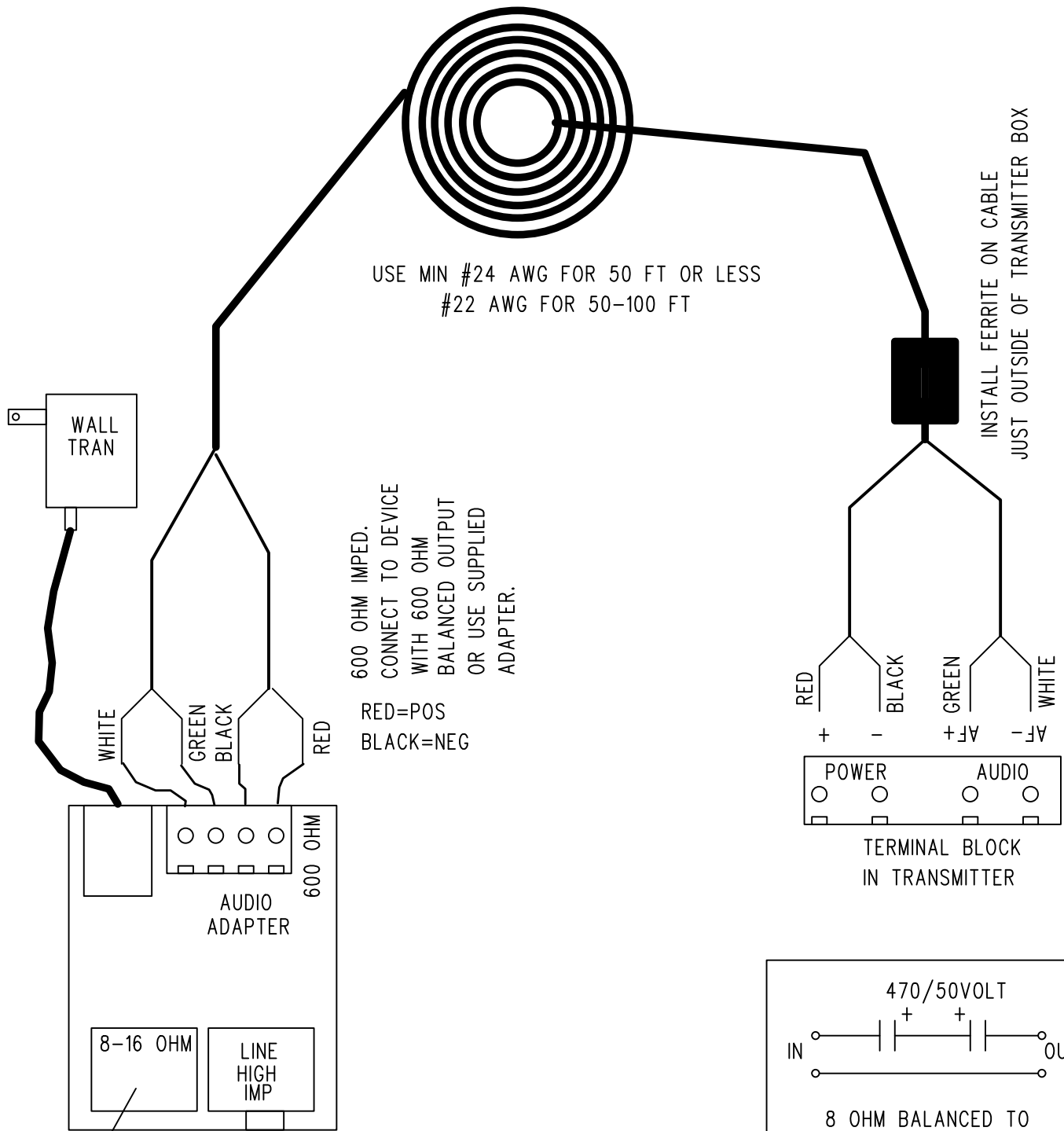

USE MIN #24 AWG FOR 50 FT OR LESS  
 #22 AWG FOR 50-100 FT

600 OHM IMPED.  
 CONNECT TO DEVICE  
 WITH 600 OHM  
 BALANCED OUTPUT  
 OR USE SUPPLIED  
 ADAPTER.

RED=POS  
 BLACK=NEG

INSTALL FERRITE ON CABLE  
 JUST OUTSIDE OF TRANSMITTER BOX

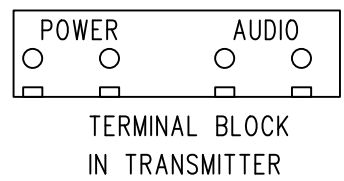
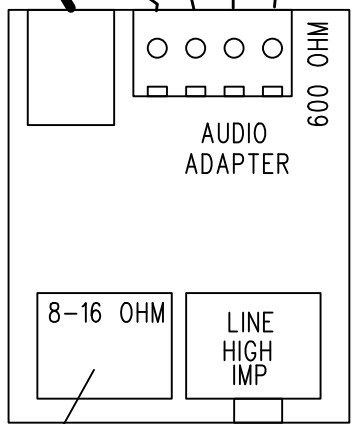

Set Switches 3&4 on to add 8 ohm load.  
 Set either switch 1 or 2 on to short ground  
 isolation resistor.

ANOTHER SUITABLE 14-18VDC SOURCE MAY BE USED

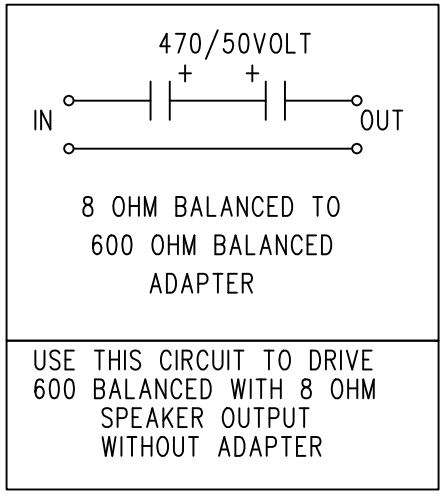

# RANGEMASTER CABLE DIAGRAM

	<b>E</b>	1.0	1.00	<b>I</b>
		1.1	.910	
		1.2	.840	
		1.3	.770	
VOLTAGE		1.4	.720	CURRENT
		1.5	.670	
		1.6	.630	
		1.7	.590	
BOTTOM AND TOP TEST JACKS		1.8	.560	MIDDLE AND BOT TEST JACKS
		1.9	.530	
		2.0	.500	
		2.1	.480	
		2.2	.455	
		2.3	.435	
		2.4	.420	
		2.5	.400	1.00 VOLT EQUALS 100 MILLI AMPS ACTUAL CURRENT
		2.6	.385	
		2.7	.370	
		2.8	.360	
		2.9	.345	
		3.0	.335	
		3.1	.325	
		3.2	.315	
		3.3	.305	
		3.4	.295	
		3.5	.285	
		3.6	.280	
		3.7	.270	
		3.8	.265	
		3.9	.255	
		4.0	.250	
		4.1	.245	
		4.2	.240	
		4.3	.233	
		4.4	.228	
		4.5	.223	
		4.6	.218	
		4.7	.213	
		4.8	.210	
		4.9	.205	
		5.0	.200	
READINGS NEEDED THAT PRODUCE 100 MILLIWAT TS		5.1	.197	
		5.2	.193	
		5.3	.189	
		5.4	.186	
		5.5	.183	
		5.6	.180	
		5.7	.177	
		5.8	.174	
		5.9	.171	